

PRODUCT SHEET

VACUUM-INSULATED - PIPING

Transfer Lines

VI Piping

VI Flex

VI CO2

VI Pipe Industry

VI Multi Transfer

Conditioning
Equipment

Components

Filling Stations

Controlling

The Vacuum Insulated Pipe, also known as VIP or SIVL, is used to transfer liquefied gases at extremely low temperatures, keeping thermal heat losses to a minimum. This rigid pipe in combination with a slim design results in an ideal and attractive alternative for non-insulated or conventional insulated piping.

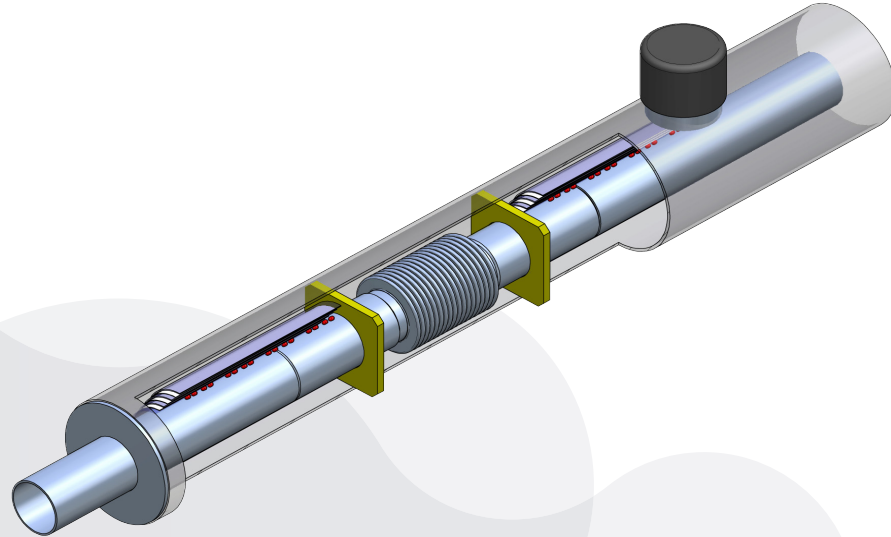

BENEFITS

Due to outstanding insulation properties, thermal heat losses are kept to a minimum

All spools are pre-fab for a fast and efficient installation

Entire stainless steel structure keeps the VIP fit for purpose for many years and is perfectly suitable for food, laboratory and pharmaceutical industries

No ice

FEATURES

All stainless steel

High vacuum insulation

Qualified welding to the highest standards

Integrated contraction bellows

Diameter process pipe: up to 8"

Pressure Rates: up to PN40

Suitable for: N2, O2, Ar, LNG, H2, He, CO2

APPLICATION

Connection of bulk storage with applications in food, medical, pharmaceutical, automotive, space and other applications

Transfer lines between cold boxes, storage tanks and truck/ship filling on air separation units

Transfer lines for small and mid-scale bulk break in LNG market

Combined into multiple transfer lines for research institutes and laboratory applications

→ www.demaco.nl

PRODUCT SHEET

VACUUM-INSULATED - PIPING

PIPE SIZE	PROCESS LINE (mm)	VACUUM JACKET (mm)	CAPACITY INDICATION (L/h) ⁽¹⁾	HEAT LOSS INDICATION (W/m)	WEIGHT INDICATION (kg/m)
DN10 small	∅ 12x1.0	∅ 40.0x1.0	300	0.30	2.1
DN10	∅ 12x1.0	∅ 63.5x1.5	300	0.40	3.4
DN15	∅ 18x1.0	∅ 63.5x1.5	500	0.45	3.5
DN25	∅ 28x1.0	∅ 63.5x1.5	2.000	0.65	4.0
1"	∅ 33.7x1.6	∅ 76.1x2.0	3.000	0.75	6.0
1½"	∅ 48.3x1.6	∅ 88.9x2.0	4.500	0.85	7.5
2"	∅ 60.3x1.6	∅ 114.3x2.0	6.000	1.0	10.0
2½"	∅ 76.1x2.0	∅ 139.7x2.0	11.500	1.3	14.0
3"	∅ 88.9x2.0	∅ 154.0x2.0	16.000	1.9	16.0
4"	∅ 114.3x2.0	∅ 168.3x3.0	27.000	2.0	22.0
6"	∅ 168.3x3.0	∅ 219.1x3.0	60.000	3.3	32.0
8"	∅ 219.1x3.0	∅ 273.0x3.0	115.000	4.4	41.0

(1) Based on saturated boiling liquid at a flow speed of 1 metre/second

INTERFACES

Johnston plug-in coupling
(can be installed without welding)

Welded couplings with vacuum or Perlite insulation
(requires welding on-site)

Universal pipe end to allow welding to any fitting, flange or application

MATERIALS

Process Pipe
1.4301/1.4306/1.4307 ~304/304L

Vacuum Jacket
1.4301/1.4306/1.4307 ~304/304L
Optional: 1.4401/1.4404 ~316/316L

Spacers
Epoxy-reinforced glass fibre

Multi-Layer Insulation
Glass paper and Aluminium foil

Supporting pipe clamps
Galvanised with rubber inlay
Stainless steel on request

DESIGN SPECIFICATIONS

Standard according to Pressure Equipment Directive (PED)

Design according to AD2000, EN13480 or ASME B31.3
(others on request)

Cleanliness level:

- Oil and grease-free
- Oxygen clean on request

Static vacuum with Multi-Layer Insulation

Bellows: 1000 cycles from +38°C till -196°C, calculated according to EN14917 or EJMA

Standard testing for each individual VIP spool:

- Dimensional check
- Pressure testing
- NDE by X-ray or PT
- Helium leak test (<1x10⁻⁹ mbarL/sec)
- Vacuum retention test after 24h at ambient temp (acceptance level <2x10⁻⁴ mbar)

DOCUMENTATION

By default, a standard manufacturer data book record is part of each project and contains:

- As-built isometrics (if applicable)
- Safety guidelines
- User manuals (if applicable)
- Declaration of conformity (if applicable)