

PRODUCT SHEET

DEGASSER

Transfer Lines

Conditioning
Equipment

Automatic Gas Vent

Degasser

Phase Separator

Subcooler

Components

Filling Stations

Controlling

The Demaco Vacuum Insulated Degasser is an upgrade of a Demaco Gas Vent. Due to a constant heat in-leak and pressure drop between tank and consumer points liquid nitrogen partly evaporates to boil-off gas. A Degasser helps you to increase the liquid nitrogen quality on the consumer points by mechanical separation of boil-off gas from liquid while in use. This degasser is part of the conditioning equipment group and like the gas vent self-operating. Standard liquid nitrogen flow consumptions up to 250 L/h are no problem. Higher capacities are custom made available on request.

Demaco Degassers are available for pressures up to PN16. Standard designed in straight (Z-shaped) and angled model and can optionally be equipped with a Johnston bayonet coupling for the GN2 blow-off making it possible to implement this device in a clean room or other industry where condense or ice build-up is not allowed.



BENEFITS

Fully automatic venting of gas during consumption

Standard DN10-25 Johnston coupling

Easy to install

FEATURES

All stainless steel

High vacuum insulation

Qualified welded to the highest standards

2 Standard pressure rating versions:

- Up to PN12
- Up to PN16

Male and female Johnston coupling models

Outlet provided with ball or solenoid valve and check valve

Standard design according Pressure Equipment Directive (PED)

APPLICATION

Maximization of outlet quality for small consumers with high quality demands like droppers

Cool down of piping

As small phase separator in combination with a back-pressure valve when no electric power or pneumatics are available

→ www.demaco.nl

 **DEMACO**

PRODUCT SHEET

DEGASSER

ANGLED MODEL

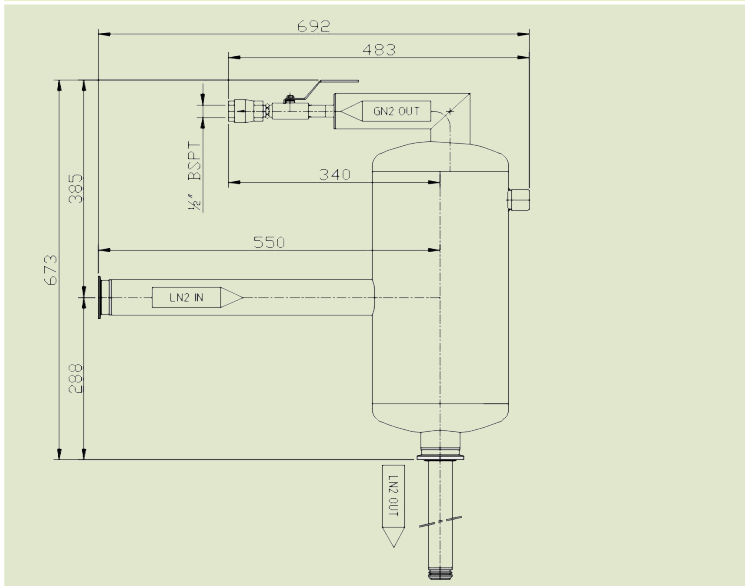

STRAIGHT MODEL

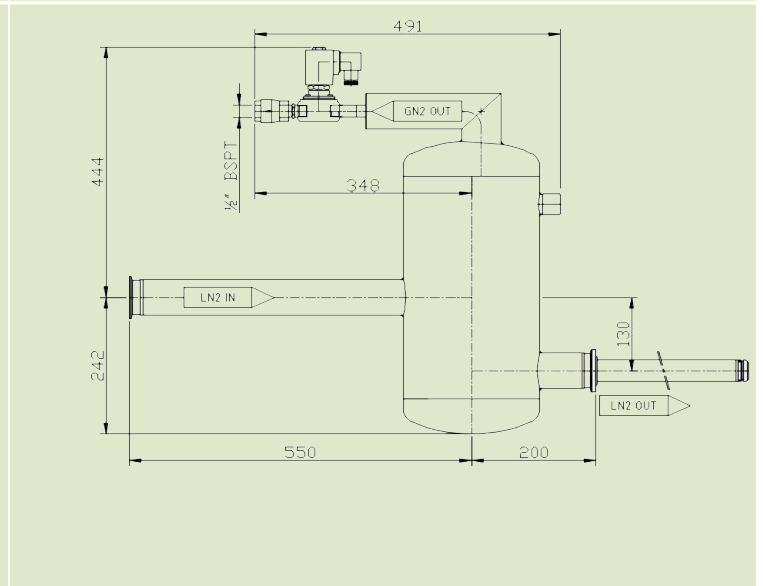

INTERFACES

Johnston coupling (can be installed without welding)

Non-insulated blow off connection for maximum connection flexibility

On request available:

- Ice free vacuum insulated blow off connection by means of Johnston coupling
- Vacuum insulated valves
- Custom interface connection

MATERIALS

Complete degasser

1.4301/1.4306/1.4307 ~304/304L

Ball or Solenoid valve

Stainless steel

Check valve

Stainless steel

Spacers

Epoxy reinforced glass fiber

Multi-Layer Insulation

Glass paper and Aluminum foil

Johnston Bayonet seal

Fe36Ni and Buna-N

DESIGN SPECIFICATIONS

Standard according Pressure Equipment Directive (PED)

Flow capacity up to 250 L/h (depending on inlet gas quality. Maximum flow depending on pre-supplied gas & liquid mixture. Larger amounts of gas results in less liquid flow)

Maximum allowable operating pressure PN12 or PN16

Cleanliness level:

- Cleaned oil and grease-free
- Oxygen clean on request

Static vacuum with Multi-Layer Insulation

Standard testing for each degasser:

- Dimensional check
- Helium leak test ($<1 \times 10^{-9}$ mbarL/sec)
- Vacuum retention test after 24h at ambient temp (acceptance level $<2 \times 10^{-4}$ mbar)

DOCUMENTATION

Standard manufacturer data book record is part of each project and contains:

- As built isometrics (if applicable)
- Safety guidelines
- User manuals